

TG185

HIGH PERFORMANCE SINGLE STAGE IEC INLET FILTER

FEATURES

- » Rated currents include **1A, 3A, 6A, 10 A, and 15A**
- » Single Stage Line Filter
- » Available with **QD** tabs or **W** (wireleads) option
- » High Performance
- » Agency Approved to UL1283/60929, CSA C22.2, EN 60939
- » Y-cap value can be adjusted to fit specifications



ELECTRICAL SCHEMATIC

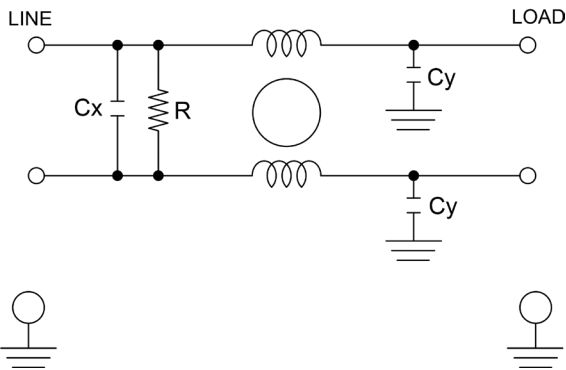

SPECIFICATIONS

OPERATING FREQUENCY	50/60Hz
IEC INLET	C14
MAX. OPERATING VOLTAGE	250V +10%
AMBIENT TEMPERATURE	-25 TO 40°C
CLIMATIC CATEGORY	25/100/21
TERMINALS (-T)	QD: 0.25" TABS WIRE LEADS
TYP. WEIGHT, LBS (KG)	0.1 (0.04)

TYPICAL LEAKAGE CURRENT

@ 250 VAC 50 Hz	0 - 0.8 mA Max.
@ 120 VAC 60 Hz	0 - 0.4 mA Max.

HIPOT RATINGS

LINE TO GROUND	2121 VDC
----------------	----------

HOW TO ORDER

TG185- X - Y - Z

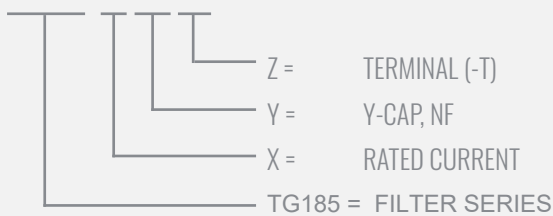

TYPICAL APPLICATIONS

- ✓ Portable Electronic Equipment
- ✓ Household Appliances
- ✓ Single-Phase Power Supplies
- ✓ Diagnostic Medical Equipment
- ✓ Fitness Systems
- ✓ Test & Measurement

TG185

HIGH PERFORMANCE SINGLE STAGE IEC INLET FILTER

MODEL NO.	RATED CURRENT, A @ 40° C	Y-CAP, nF	LEAKAGE CURRENT, mA @ 250V AC, 50 Hz / @ 120V AC, 60 Hz		TERMINAL OPTIONS		MAX. DIMENSIONS" (MM)		
					(QD) OUTPUT	(W) OUTPUT	WIDTH	(LENGTH)	HEIGHT
TG185-1-0-Q D	1	0	-	-	✓		1.97" (50)	3.0" (76.5)	0.89" (22.7)
TG185-1-0-W	1	0	-	-		✓	*	*	*
TG185-1-.47-Q D	1	0.47	0.07	0.04	✓		1.97" (50)	3.0" (76.5)	0.89" (22.7)
TG185-1-.47-W	1	0.47	0.07	0.04		✓	*	*	*
TG185-1-1-Q D	1	1	0.15	0.09	✓		1.97" (50)	3.0" (76.5)	0.89" (22.7)
TG185-1-1-W	1	1	0.15	0.09		✓	*	*	*
TG185-1-2.2-Q D	1	2.2	0.34	0.19	✓		1.97" (50)	3.0" (76.5)	0.89" (22.7)
TG185-1-2.2-W	1	2.2	0.34	0.19		✓	*	*	*
TG185-1-4.7-Q D	1	4.7	0.80	0.40	✓		1.97" (50)	3.0" (76.5)	0.89" (22.7)
TG185-1-4.7-W	1	4.7	0.80	0.40		✓	*	*	*
TG185-3-0-Q D	3	0	-	-	✓		1.97" (50)	3.0" (76.5)	0.89" (22.7)
TG185-3-0-W	3	0	-	-		✓	*	*	*
TG185-3-.47-Q D	3	0.47	0.08	0.04	✓		1.97" (50)	3.0" (76.5)	0.89" (22.7)
TG185-3-.47-W	3	0.47	0.08	0.04		✓	*	*	*
TG185-3-1-Q D	3	1	0.18	0.09	✓		1.97" (50)	3.0" (76.5)	0.89" (22.7)
TG185-3-1-W	3	1	0.18	0.09		✓	*	*	*
TG185-3-2.2-Q D	3	2.2	0.40	0.20	✓		1.97" (50)	3.0" (76.5)	0.89" (22.7)
TG185-3-2.2-W	3	2.2	0.40	0.20		✓	*	*	*
TG185-3-4.7-Q D	3	4.7	0.80	0.40	✓		1.97" (50)	3.0" (76.5)	0.89" (22.7)
TG185-3-4.7-W	3	4.7	0.80	0.40		✓	*	*	*
TG185-6-0-Q D	6	0	-	-	✓		1.97" (50)	3.0" (76.5)	0.89" (22.7)
TG185-6-0-W	6	0	-	-		✓	*	*	*
TG185-6-.47-Q D	6	0.47	0.08	0.04	✓		1.97" (50)	3.0" (76.5)	0.89" (22.7)
TG185-6-.47-W	6	0.47	0.08	0.04		✓	*	*	*
TG185-6-1-Q D	6	1	0.18	0.09	✓		1.97" (50)	3.0" (76.5)	0.89" (22.7)
TG185-6-1-W	6	1	0.18	0.09		✓	*	*	*
TG185-6-2.2-Q D	6	2.2	0.40	0.20	✓		1.97" (50)	3.0" (76.5)	0.89" (22.7)
TG185-6-2.2-W	6	2.2	0.40	0.20		✓	*	*	*
TG185-6-4.7-Q D	6	4.7	0.80	0.40	✓		1.97" (50)	3.0" (76.5)	0.89" (22.7)
TG185-6-4.7-W	6	4.7	0.80	0.40		✓	*	*	*
TG185-10-0-Q D	10	0	-	-	✓		1.97" (50)	3.0" (76.5)	0.89" (22.7)
TG185-10-0-W	10	0	-	-		✓	*	*	*
TG185-10-.47-Q D	10	0.47	0.08	0.04	✓		1.97" (50)	3.0" (76.5)	0.89" (22.7)
TG185-10-.47-W	10	0.47	0.08	0.04		✓	*	*	*

TG185

HIGH PERFORMANCE SINGLE STAGE IEC INLET FILTER

MODEL NO.	RATED CURRENT, A @ 40° C	Y-CAP, nF	LEAKAGE CURRENT, mA @ 250V AC, 50 Hz / @ 120V AC, 60 Hz		TERMINAL OPTIONS		MAX. DIMENSIONS" (MM)		
					(QD) OUTPUT	(W) OUTPUT	WIDTH	(LENGTH)	HEIGHT
TG185-10-1-Q D	10	1	0.18	0.09	✓		1.97" (50)	3.0" (76.5)	0.89" (22.7)
TG185-10-1-W	10	1	0.18	0.09		✓	*	*	*
TG185-10-2.2-Q D	10	2.2	0.40	0.20	✓		1.97" (50)	3.0" (76.5)	0.89" (22.7)
TG185-10-2.2-W	10	2.2	0.40	0.20		✓	*	*	*
TG185-10-4.7-Q D	10	4.7	0.80	0.40	✓		1.97" (50)	3.0" (76.5)	0.89" (22.7)
TG185-10-4.7-W	10	4.7	0.80	0.40		✓	*	*	*
TG185-15-0-Q D	15	0	-	-	✓		1.97" (50)	3.06" (77.8)	0.88" (22.4)
TG185-15-0-W	15	0	-	-		✓	*	*	*
TG185-15-0.47-Q D	15	0.47	0.08	0.04	✓		1.97" (50)	3.06" (77.8)	0.88" (22.4)
TG185-15-0.47-W	15	0.47	0.08	0.04		✓	*	*	*
TG185-15-1-Q D	15	1	0.18	0.09	✓		1.97" (50)	3.06" (77.8)	0.88" (22.4)
TG185-15-1-W	15	1	0.18	0.09		✓	*	*	*
TG185-15-2.2-Q D	15	2.2	0.40	0.20	✓		1.97" (50)	3.06" (77.8)	0.88" (22.4)
TG185-15-2.2-W	15	2.2	0.40	0.20		✓	*	*	*
TG185-15-4.7-Q D	15	4.7	0.80	0.40	✓		1.97" (50)	3.06" (77.8)	0.88" (22.4)
TG185-15-4.7-W	15	4.7	0.80	0.40		✓	*	*	*

*Contact factory for dimensions.

TG185

HIGH PERFORMANCE SINGLE STAGE IEC INLET FILTER

TG185 MECHANICAL OUTLINES (MM)

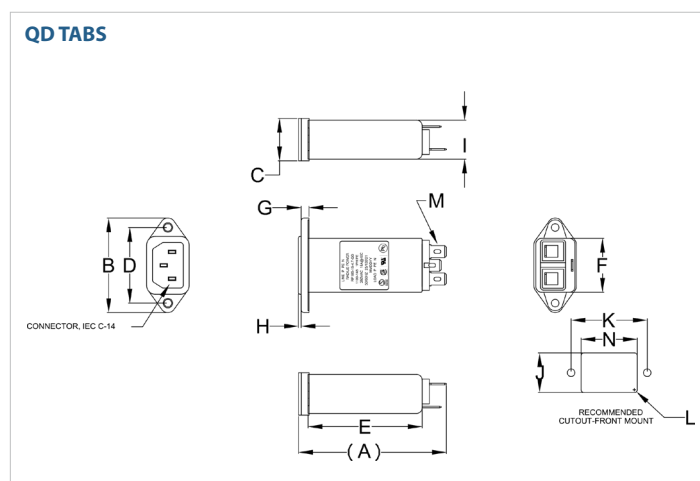

SERIES	(A)	B	C	D	E	F	G	H	I	J	K	L	M	N
QD TABS (1/3/6/10A)	3.0" (76.5)	1.97" (50)	0.89" (22.7)	1.57" (40)	2.36" (60)	1.08" (27.5)	0.11" (2.7)	0.07" (1.8)	0.80" (20.2)	0.83" (21)	1.57" (40)	N/A	QD, MALE, 6.35, 3x	1.16" (29.5)
QD TABS (15A)	3.06" (77.8)	1.97" (50)	0.88" (22.4)	1.57" (40)	2.40" (61)	1.16" (29.5)	0.16" (4.1)	0.06" (1.5)	0.85" (21.6)	0.83" (21)	1.57" (40)	0.05", 4x R1.5, 4x	0.25", 3x QD, MALE, 6.35, 3x	1.16" (29.5)

TYPICAL TOLERANCE: +/-0.02" (0.50MM)

TYPICAL INSERTION LOSS, dB (50/50 Ohm)

Amps	Freq (MHz)	Insertion Loss (dB)				
		0.15	0.5	1.0	10	30
1	CM (dB)	46	55	55	55	50
	DM (dB)	22	38	40	40	50
3	CM (dB)	36	50	55	55	50
	DM (dB)	22	35	50	60	60
6	CM (dB)	22	35	42	55	60
	DM (dB)	20	32	40	50	55
10	CM (dB)	20	32	28	55	55
	DM (dB)	20	32	40	58	60
15	CM (dB)	14	22	30	50	58
	DM (dB)	15	32	40	54	70