

**1 Part No.**

**TGIF**    **0740**    **—**    **3R3**    **M**  
 ①            ②            ③            ④

- ① Product Type: VRKL Series
- ② Dimensions: 7.0×40.0mm
- ③ Inductance: 3R3 = 3.30μH
- ④ Inductance Tolerance: M = ±20%



**2 Appearance and Dimensions (mm)**

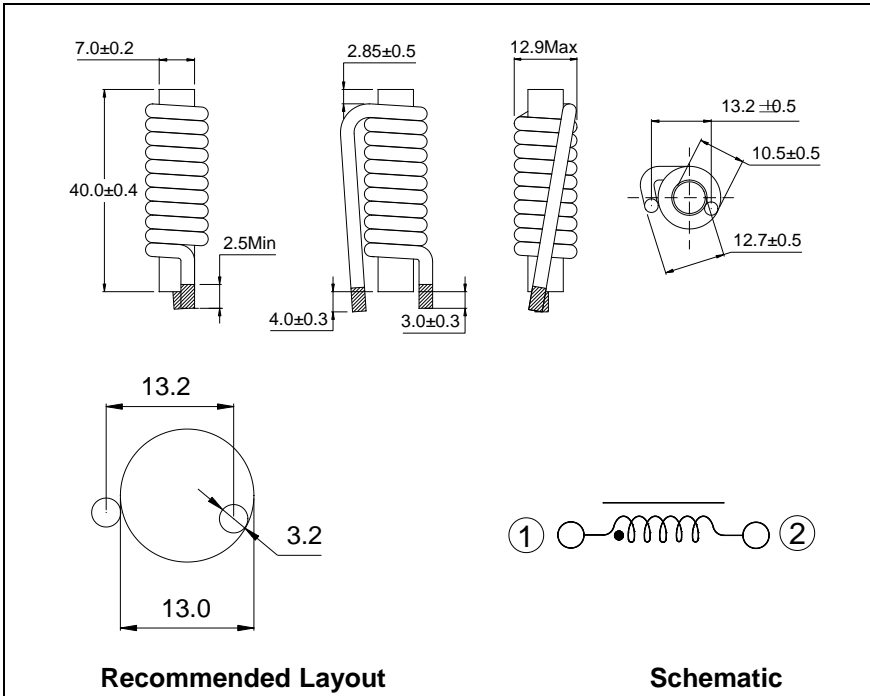

**3 Features**

Core Material	Ferrite
Wire	Enameled copper
Terminal Finish	Sn
Weight	27.16g
Environmental	RoHS compliant Halogen free
Moisture Sensitivity Level (MSL)	Level 1
Operating temperature range: -40°C ~ +150°C (Temperature Rise included)	
Storage temperature range: -40°C ~ +155°C	

**4 Electrical Characteristics**

Part No. 型号	Inductance (μH) ※1	D.C.R. (mΩ)		Saturation current (A) ※2	Temperature rise current (A) ※3
	±20%	Typical	Max	Typical	Typical
TGIF0740-3R3M	3.30	1.11	1.30	31.0	30.0

■ All data is tested based on 25°C ambient temperature.

※1 Inductance measure condition at 1.0kHz, 0.25V.

※2 Saturation current: the actual value of DC current when the inductance decrease 20% of its initial value.

※3 Temperature rise current: the actual value of DC current when the temperature rise is ΔT40°C(Ta=25°C).

※ Special remind: Circuit design, component placement, PCB size and thickness, cooling system and etc. all will affect the product temperature. Please verify the product temperature in the final application.

**5 Saturation Current vs Temperature Rise Current Curve**

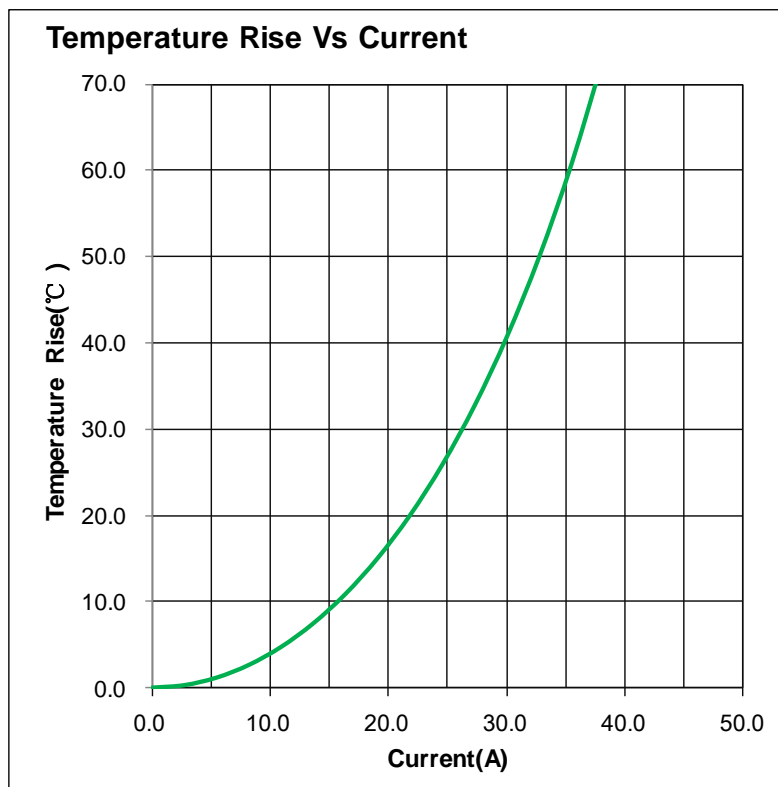
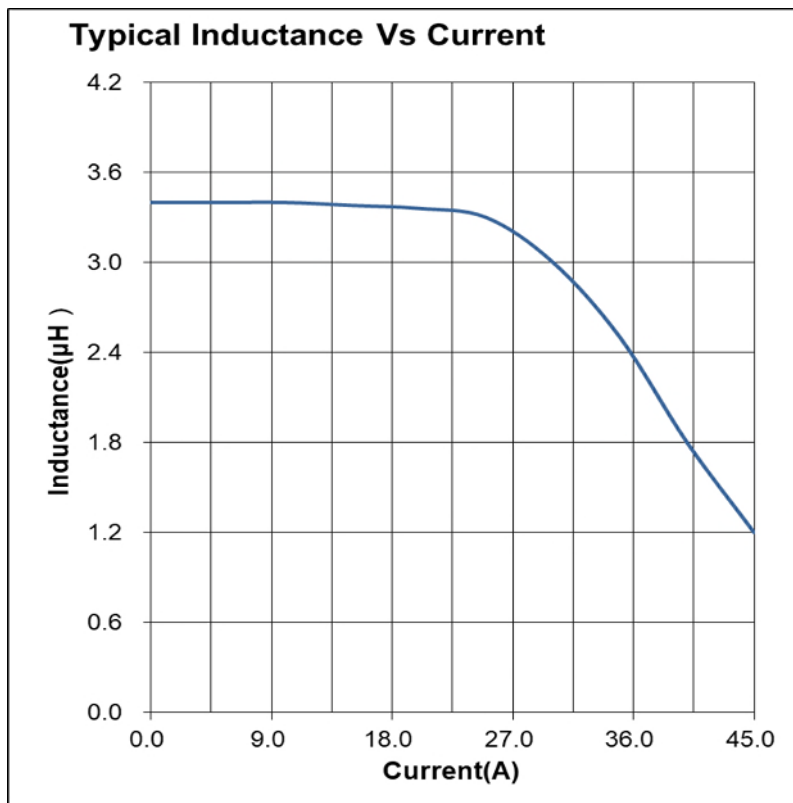

## 6 Packing Specification

### 6.1 Plastic Tray Dimensions (mm)

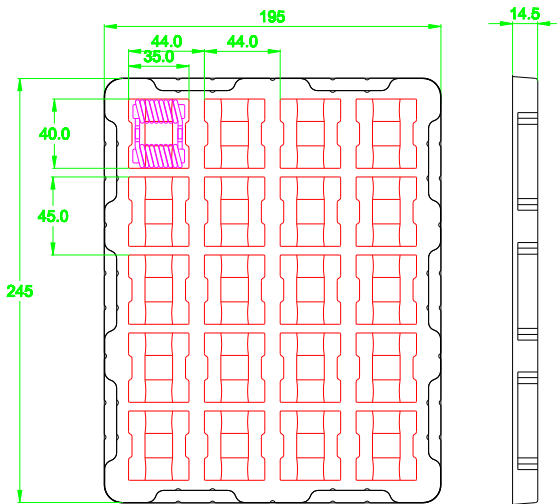

Packaging Unit (Pcs)	Material
24	APET

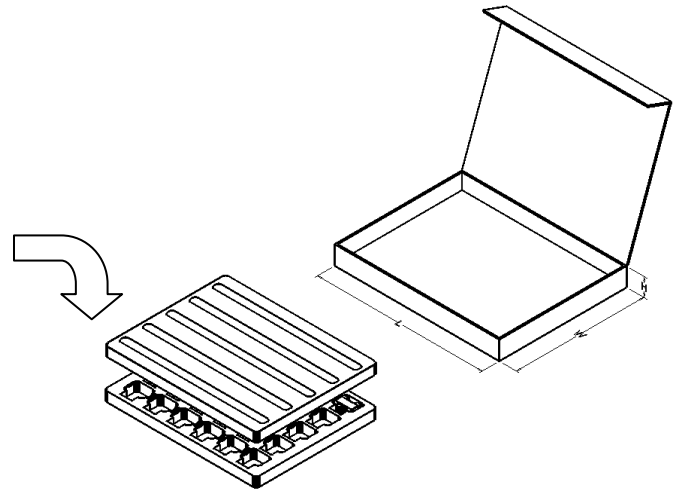

L typ	W typ	H typ	No. of Tray (Pcs)	Packaging Unit(Pcs)	Material
265	205	36	2	48	Paper

### 6.2 Packing(mm)

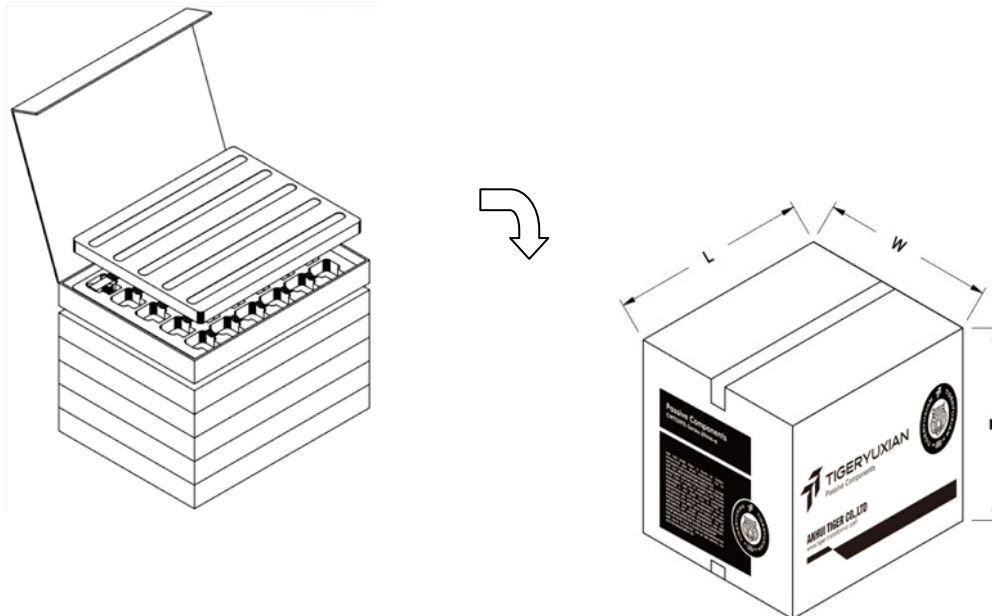

L typ	W typ	H typ	No. of Inner Carton	Packaging Unit( Pcs)	Material
275	232	255	6	288	Paper

## 7 General characteristics

### 7.1 Temperature characteristics

Inductance coefficient :  $(0 \sim 2000) \times 10^{-6} / ^\circ\text{C}$

### 7.2 Terminal strength test

No electrode detachment should be found when the device is pushed in two directions of X and Y with the force of 5N for 10 seconds after soldering between copper plate and the electrodes.

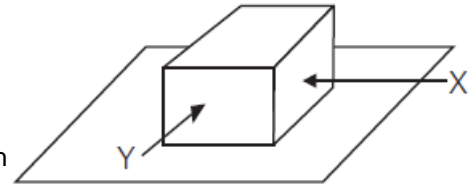

### 7.3 Vibration test

Inductance deviation within  $\pm 5\%$  after vibration for 1 hour, in each of the at sweep vibration (10~55~10Hz) with 1.5mm P-P amplitudes.

### 7.4 Shock test

Inductance deviation within  $\pm 5\%$  after being dropped once with  $981\text{m/s}^2$  (100G) shock attitude upon a rubber block method shock testing machine, in three different orientations.

### 7.5 Humidity test

Inductance deviation within  $\pm 5\%$ , after 96 hours in 90~95% relative humidity at  $40 \pm 2^\circ\text{C}$  and 1 hour drying under normal condition.

### 7.6 High temperature operating life test

Being stored in a chamber of temperature  $85 \pm 2^\circ\text{C}$  for  $96 \pm 4$  hours with DC 30.0A.

And then it shall be subjected to standard atmosphere conditions for 1 to 2 hours,

after which measurement shall be made and compared with the initial result, inductance deviation within  $\pm 5\%$

### 7.7 Thermal shock test

Being subjected to  $-40 \pm 2^\circ\text{C}$  for 30 minutes, then to  $125 \pm 2^\circ\text{C}$  for 30 minutes (Transition time is 1 minute Max). This constitutes one cycle. After 100 cycles, inductance deviation within  $\pm 5\%$ .

## 8 Notice of Use

8.1 Special remind: Circuit design, component placement, PCB size and thickness, cooling system and etc. all will affect the product temperature. Please verify the product temperature in the final application.

8.2 Product in packing storage condition : temperature  $5 \sim 40^\circ\text{C}$ ,  $\text{RH} \leq 70\%$ .

If taking out for use, the remaining products should be sealed in plastic bags and preserved in accordance with the above conditions, to avoid oxidation of terminals (electrodes), affecting soldering status.

8.3 A storage of Codaca Electronic products for longer than 12 months is not recommended, Within other effects, the terminals may suffer degradation, resulting in bad solderability. Therefore, all products shall be used within the period of 12 months based on the day of shipment.

8.4 Do not keep products in unsuitable storage conditions, such as areas susceptible to high temperatures, high humidity, dust or corrosion.

8.5 Always handle products with care.

8.6 Don't touch electrodes directly with bare hands as oil secretions may inhibit soldering. Always ensure optimum conditions for soldering.

8.7 When this product will be used on a similar or new project to the original one, sometimes it might be unable to satisfy the specifications due to different condition of usage.

8.8 This inductor itself does not have any protective function in abnormal condition, such as overload, short-circuit, open-circuit conditions, etc. Therefore, it shall be confirmed that there is no risk of smoke, fire, dielectric withstand voltage, insulation resistance, etc., or use in abnormal conditions protective devices or protection circuit in the end product.

8.9 Hi-Pot test with higher voltage than spec value will damage insulating material and shorten its life.

8.10 If using in potting compound, the magnet wire coating might be damaged, please consult with us.

8.11 Refrain from rinsing coils. If necessary, please consult with us.