

Outline:

- Small footprint power inductors designed for maximum efficiency And low cost
- Industry-standard pin spacings; protective PVC sleeve is available for extra demand
- In addition to the standard versions of inductors shown here custom inductors are available to meet your exact requirements

Features:

- Core material:Ferrite
- Environmental: RoHS, Reach compliant ,Halogen free
- Weight:0.67g
- Moisture Sensitivity:Level (MSL) 1 (unlimited floor life at 30°C /85% relative humidity).
- Operating temperature range: $-40^{\circ}\text{C}\sim+125^{\circ}\text{C}$ (including coil's self temperature rise)
- Storage temperature range: $-40^{\circ}\text{C}\sim+125^{\circ}\text{C}$

Application:

- Ideal for noise filtering in power amplifiers,power supplies and Speaker crossover networks.
- buck converter,network communication equipment, and etc

1 Electrical Characteristics

Part No.	Inductance (μH) $\times 1$	D.C.R. ($\text{m}\Omega$)		Isat	Irms
		Typical	Max	(A) $\times 2$	(A) $\times 3$
TGS10606-1R2M	1.20 $\pm 20\%$	10.5	12.6	8.00	6.30
TGS10606-2R2M	2.20 $\pm 20\%$	13.8	16.5	6.00	5.80
TGS10606-3R3M	3.30 $\pm 20\%$	17.0	20.5	5.40	5.02
TGS10606-4R7M	4.70 $\pm 20\%$	22.6	27.1	4.15	4.30
TGS10606-6R8M	6.80 $\pm 20\%$	27.5	33.0	3.70	3.43
TGS10606-8R2M	8.20 $\pm 20\%$	31.4	37.7	3.25	3.18
TGS10606-100K	10.0 $\pm 10\%$	37.6	45.1	3.00	2.98
TGS10606-120K	12.0 $\pm 10\%$	41.9	50.3	2.75	2.87
TGS10606-150K	15.0 $\pm 10\%$	54.3	65.2	2.38	2.62
TGS10606-180K	18.0 $\pm 10\%$	59.9	71.9	2.30	2.25
TGS10606-220K	22.0 $\pm 10\%$	77.7	93.2	2.00	1.97
TGS10606-270K	27.0 $\pm 10\%$	87.9	105	1.80	1.84
TGS10606-330K	33.0 $\pm 10\%$	110	132	1.71	1.65
TGS10606-390K	39.0 $\pm 10\%$	134	161	1.52	1.60
TGS10606-470K	47.0 $\pm 10\%$	152	182	1.26	1.44
TGS10606-560K	56.0 $\pm 10\%$	173	208	1.22	1.28
TGS10606-680K	68.0 $\pm 10\%$	213	255	1.18	1.19
TGS10606-820K	82.0 $\pm 10\%$	254	304	1.08	1.09
TGS10606-101K	100 $\pm 10\%$	316	379	0.95	0.92
TGS10606-121K	120 $\pm 10\%$	378	454	0.84	0.88
TGS10606-151K	150 $\pm 10\%$	452	542	0.78	0.78
TGS10606-181K	180 $\pm 10\%$	520	624	0.70	0.74
TGS10606-221K	220 $\pm 10\%$	705	846	0.65	0.65
TGS10606-271K	270 $\pm 10\%$	839	1,007	0.61	0.55
TGS10606-331K	330 $\pm 10\%$	1,040	1,248	0.53	0.49
TGS10606-391K	390 $\pm 10\%$	1,158	1,390	0.49	0.46
TGS10606-471K	470 $\pm 10\%$	1,432	1,718	0.45	0.42
TGS10606-561K	560 $\pm 10\%$	1,854	2,225	0.42	0.39
TGS10606-681K	680 $\pm 10\%$	2,014	2,417	0.37	0.35
TGS10606-821K	820 $\pm 10\%$	2,405	2,886	0.33	0.33
TGS10606-102J	1,000 $\pm 5\%$	3,420	4,104	0.30	0.27

2 Product Dimensions (mm)

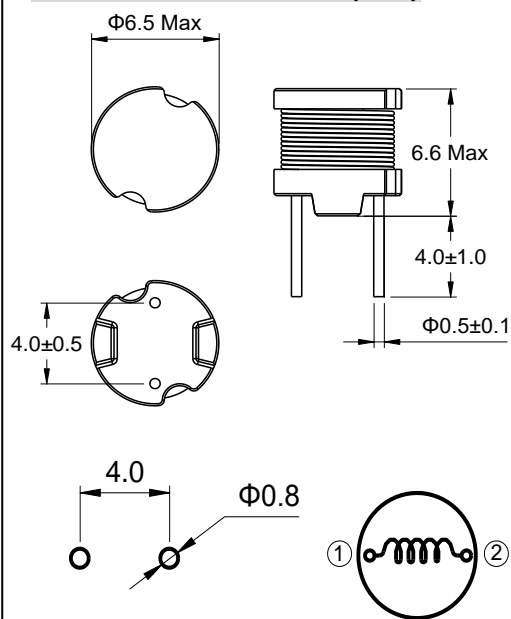

Typical Hole Pattern

Schematic

All data is tested on 25°C ambient temperature

1. If the inductance is smaller than 1mH, can be measured at 100kHz,0.1V, otherwise at 10kHz,0.25V
2. Isat: the actual value of DC current when the Inductance decrease 20% of its initial value
3. Irms: the actual value of DC current when the the temperature rise is $\Delta T 40^{\circ}\text{C}$ ($T_a = 25^{\circ}\text{C}$)

3 Saturation Current vs Temperature Rise Current Curve

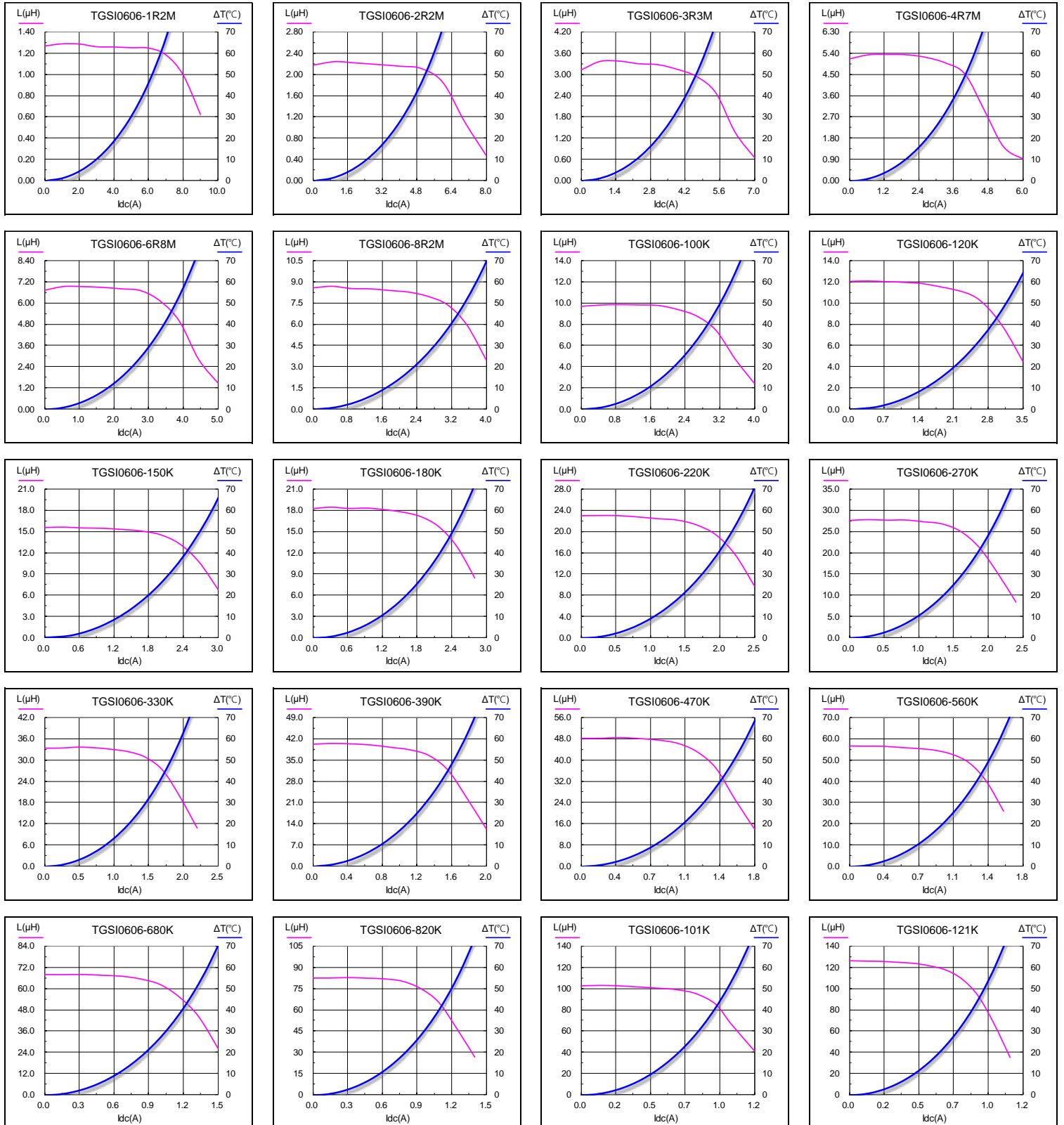

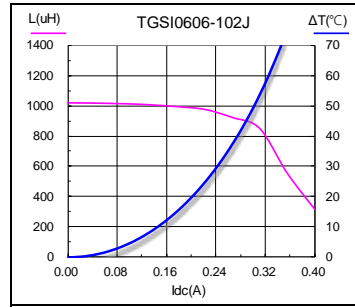
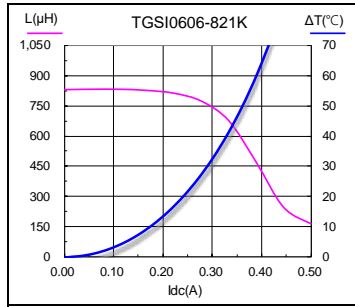
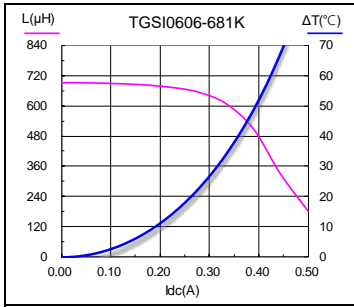
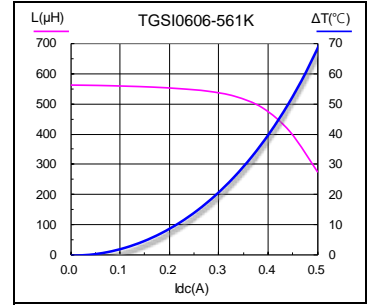
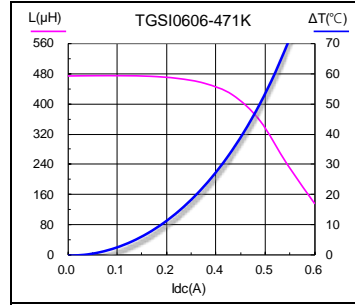
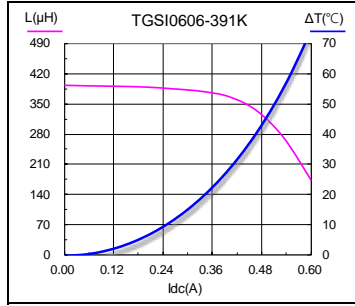
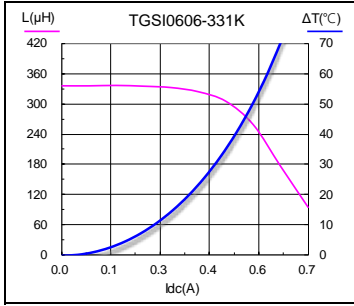
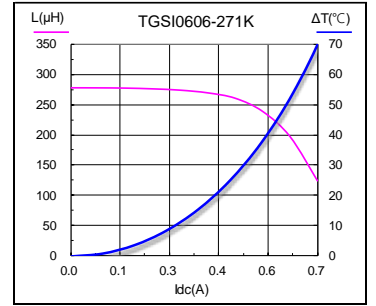
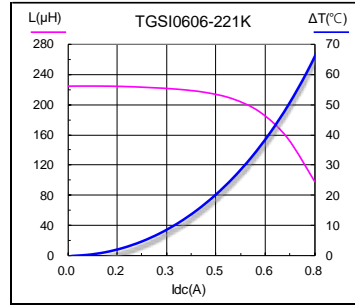
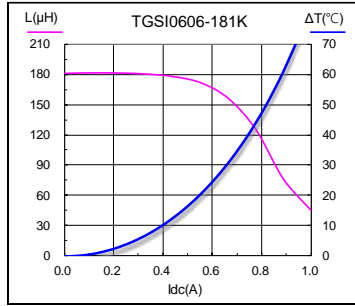
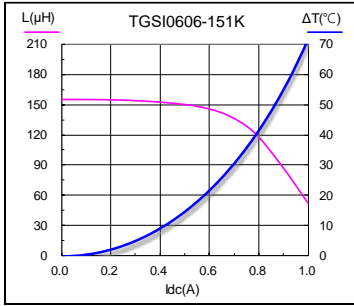

4 Packing Specification

4.1 Packing(mm)

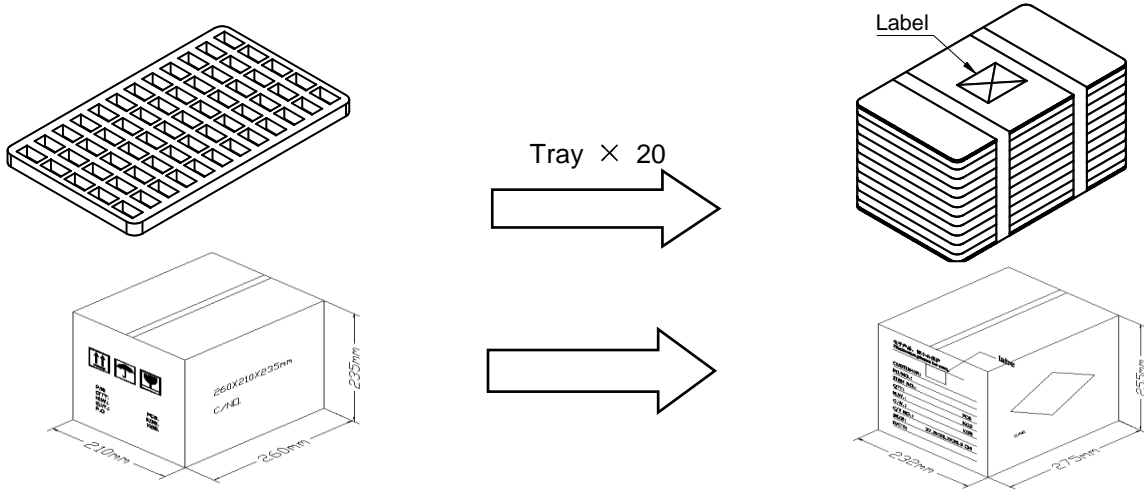

4.2 Carton Dimensions and Packing Quantity

■ Inner Carton: 245*185*9.5mm ■ Inner Carton: 260*210*235mm ■ Out Carton : 275*232*255mm

Product Series	Quantity / Bag	Inner Carton Quantity	Out Carton Quantity
TGSIS0606	182pcs	(182 × 20) = 3640pcs	(3640 × 1) = 3640pcs

4.3 Label Making

The following items will be marked on the tray of product label and shipping label.

Production Label
■ Packing No.
■ Quantity
■ Shipment Date
■ Part No.
■ Customer Part No.
■ Customer Po No.

Shipping Label
■ Packing No.
■ Quantity
■ Shipment Date
■ Part No.
■ Customer Part No.
■ Customer Po No.

5 Notice of Use

- 5.1 Special remind:Circuit design, component placement, PCB size and thickness, cooling system and etc. all will affect the product temperature. Please verify the product temperature in the final application.
- 5.2 Product in packing storage condition:temperature 5~40°C, RH≤70%.
If taking out for use, the remaining products should be sealed in plastic bags and preserved in accordance with the above conditions, to avoid oxidation of terminals (electrodes), affecting soldering status.
- 5.3 A storage of Codaca Electronic products for longer than 12 months is not recommended, Within other effects, the terminals may suffer degradation, resulting in bad solderability. Therefore, all products shall be used within the period of 12 months based on the day of shipment.
- 5.4 Do not keep products in unsuitable storage conditions, such as areas susceptible to high temperatures, high humidity, dust or corrosion.
- 5.5 Always handle products with care.
- 5.6 Don't touch electrodes directly with bare hands as oil secretions may inhibit soldering.
Always ensure optimum conditions for soldering.
- 5.7 When this product will be used on a similar or new project to the original one, sometimes it might be unable to satisfy the specifications due to different condition of usage.
- 5.8 This inductor itself does not have any protective function in abnormal condition, such as overload, short-circuit, open-circuit conditions, etc. Therefore, it shall be confirmed that there is no risk of smoke, fire, dielectric withstand voltage, insulation resistance, etc., or use in abnormal conditions protective devices or protection circuit in the end product.
- 5.9 Hi-Pot test with higher voltage than spec value will damage insulating material and shorten its life.
- 5.10 If using in potting compound, the magnet wire coating might be damaged, please consult with us.
- 5.11 Refrain from rinsing coils. If necessary, please consult with us.